

Permissible Surface defects of AlN substrates (visual inspection) for “A” face only

(acc. to ASTM F109-73)

Burrs

Fragment of excess material or foreign particle adhering to the surface not allowed

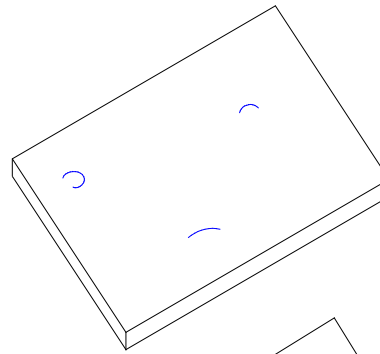

Pits, Holes and Pocks

A deep depression or void

$\varnothing > 0,5$ mm not allowed,

$\varnothing < 0,5$ mm one per square inch allowed and/or

$\varnothing < 0,1$ mm two per square inch allowed

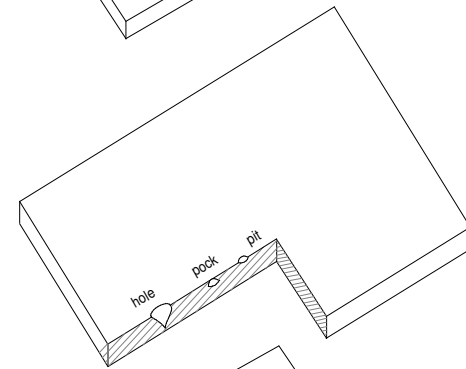

Blisters

Bubble or inclusion under the surface

Which, if broken, could form a pit, pock or hole:

one per square inch $\varnothing < 0,5$ mm allowed

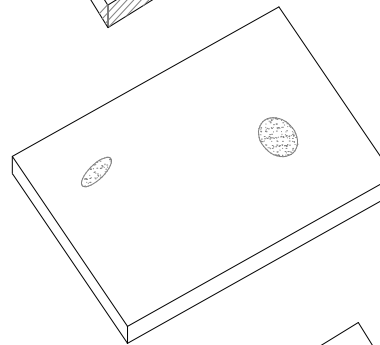

Scratches

Relatively long, narrow, shallow groove or cut in the surface

One per square inch with $< 5\mu\text{m}$ depths, $< 10\mu\text{m}$ width and

< 6 mm length allowed

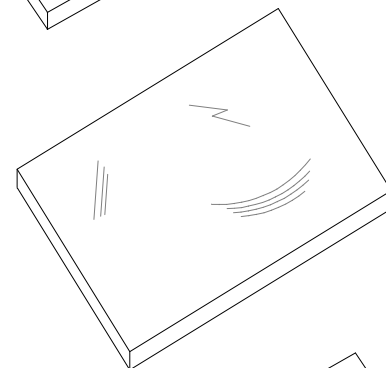

Chipping

Open: Material broken off along an edge or corner

Closed: Material has not broken off or separated

One chip per inch edge length with

$l < 5$ mm

$w < 0,2$ mm

$d < 0,2$ mm

allowed

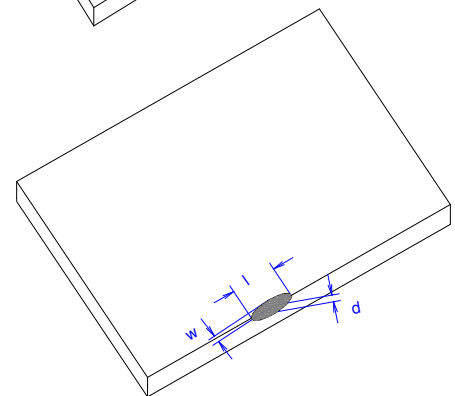
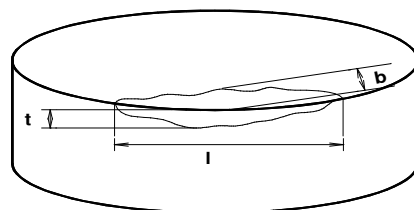

Cracks

Line of fracture without complete separation not allowed